



HMM[®]
SYSTEMS

HM Tamper Evident Labeller

- follow us



HM Tamper Evident



The HM Tamper Evident labeller is a robust solution in compliance with the FMD (European Union Falsified Medicine Directive)

The HM Tamper Evident labeler is a robust solution in compliance with the FMD (European Union Falsified Medicine Directive).

HM Systems has +50 years of experience, designing and documenting marking and labelling solutions. We also has experience within the pharmaceutical industry and supply solutions in accordance with GAMP.

Starting in early 2019 pharmaceutical serialization will become a legal requirement for companies in the European Union (FMD).

In the US, it became compulsory from November 2017 under the United States Drug Supply Chain Security Act (DSCSA).

Part of the directive is the tamper evident proof of the serialized cartons.

The HM Tamper Evident labeller is prepared for easy integration with interface to MES, Scada etc. based on open standards such as: OPC, JSON or XML.



Compact and easy to integrate

The HM Tamper Evident Labeller has a small foot-print and it is very easy to fit in both in new and existing packaging lines. The Tamper Evident Labeller is extremely flexible in its application.

The easy integration into existing systems and the intuitive operation make the HM Tamper Evident Labeller a valuable asset.

Flexible and user-friendly

The labeller has also been designed with focus on product safety and user friendliness. From our many years in the pharmaceutical industry we know the importance of reducing time spent on batch start/stop, line clearance, cleaning and maintenance.

Safe synchronization

The machine can stop and restart the process at any position and still maintain a safe product register.

Advantages and benefits

Advantages

- Efficient implementation of tamper-evident requirements using sealing labels
- High reliability thanks to the use of proven standard modules
- Entirely standard equipment from the outset
- The key component is the tried-and-tested HM 400TE label applicator
- Label applied approval
- Suitable for a wide range of folding boxes, see technical data for more information.

Benefits

- Well proven labelling concept
- High process reliability
- Closing and sealing - "safe seal" with transparent or non-transparent labels
- Reverse Tuck end and Airplane closing cartons can be sealed
- Apply one or two tamper evident labels including check in any position
- Easy adjustable to different product sizes, from small cartons to larger cartons
- Control of label on product, with an automatic reject system for non approved products
- Easy format change, even between airplane and RTE cartons

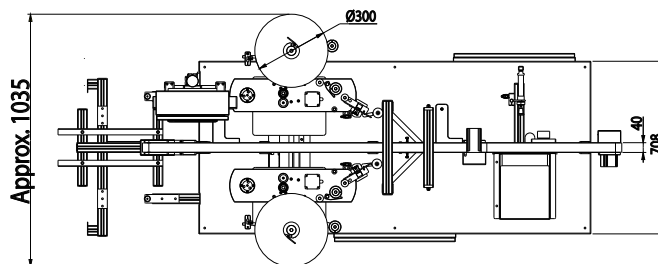
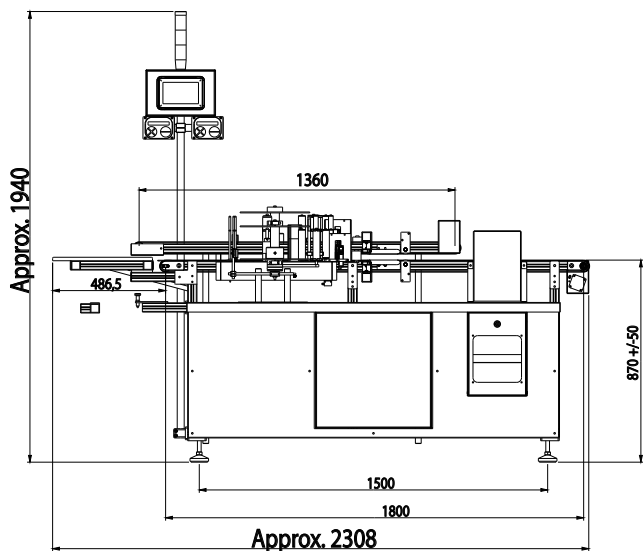

TECHNICAL DATA

LABEL CORNER APPLICATION:

Left & right side on top/bottom of carton, in running direction

Leading edge min 45mm + label diameter, max 210 mm

Height min 10 mm, max 75 mm

Printed side min 10 mm, max 150 mm

HM 400TE-120 label dispensers

Gap sensors for transparent labels

Low label sensors

Remote display

Missing label detection station (label on box detection)

Blow-out ejection

Eject-bin with lock

Synchronized top belt with spindle position indicator. (Not on automatic model)

Label corner application: Left & right side on top/bottom of carton, in travel direction

Left/right spindles with spindle position indicators. (Not on automatic model)

Horizontal spindles with spindle position indicators. (Not on automatic model)

PLC Controlled

Siemens S7-1200 PLC

7" Multi-color touch screen display

Beacon: Red/Yellow/Green

Upstream alarm signal

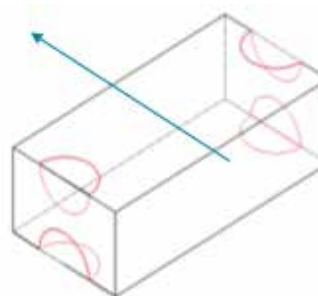

OPTIONS

Lights Warning light

Frame in stainless steel

- Two HM-400TE 120 labellers 40 m/min.
- Main conveyor with high grip silicone belt
- Adjustable top conveyor
- Control box with Siemens S7 PLC
- Speed controllers for variable speed
- 7" Multi color touch screen
- Blow nozzle for reject
- Speed controllers for flexible speed
- Warning light

User-friendly display controlling the labeller

We reserve the right to make changes ©

- follow us



H M[®]
SYSTEMS

HM Systems A/S / Melskov Allé 6 / DK-6100 Haderslev
T +45 7454 0933 / hm-systems.com / mail@hm-systems.dk